

# TC74HC238AP, TC74HC238AF

## 3-TO-8 LINE DECODER

The TC74HC238A is a high speed CMOS 3-to-8 DECODER fabricated with silicon gate C<sup>2</sup>MOS technology.

It achieves the high speed operation similar to equivalent LSTTL while maintaining the CMOS low power dissipation. When the device is enabled, 3 Binary Select inputs (A, B and C) determine which one of the outputs (Y0-Y7) will go high.

When enable input G1 is held low or either G2A or G2B is held high, decoding function is inhibited and all the outputs go low. G1, G2A, and G2B inputs are provided ease cascade connection and for use as an address decoder for memory systems.

All inputs are equipped with protection circuits against static discharge or transient excess voltage.

### FEATURES :

- High Speed.....  $t_{pd} = 14ns$ (typ.) at  $V_{CC} = 5V$
- Low Power Dissipation.....  $I_{CC} = 4\mu A$ (Max.) at  $T_a = 25^\circ C$
- High Noise Immunity.....  $V_{NIH} = V_{NIL} = 28\% V_{CC}$  (Min.)
- Output Drive Capability..... 10 LSTTL Loads
- Symmetrical Output Impedance...  $|I_{OH}| = |I_{OL}| = 4mA$ (Min.)
- Balanced Propagation Delays.....  $t_{PLH} \approx t_{PHL}$
- Wide Operating Voltage Range...  $V_{CC}$  (opr.) = 2V~6V
- Pin and Function Compatible with 74LS238

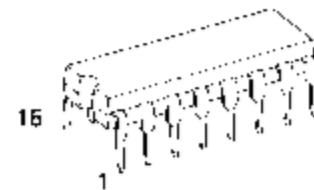

P (DIP16-P-300-2.54A)  
Weight : 1.00g (Typ.)



F (SOP16-P-300-1.27)  
Weight : 0.18g (Typ.)

### PIN ASSIGNMENT

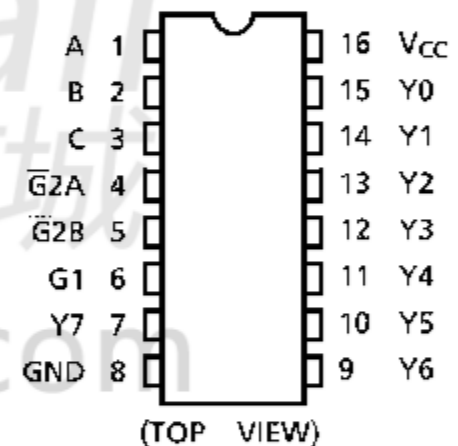

### IEC LOGIC SYMBOL

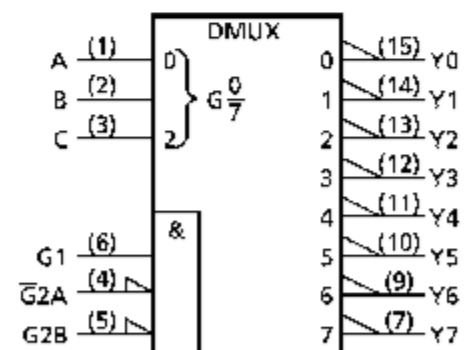
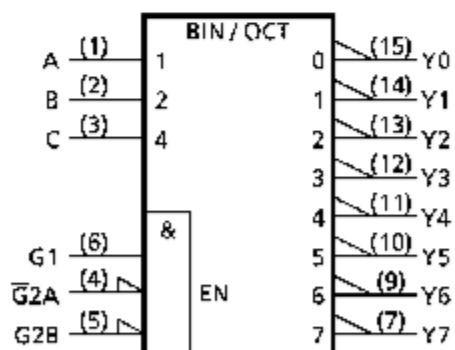

**TRUTH TABLE**

INPUTS						OUTPUTS								SELECTED OUTPUT	
ENABLE			SELECT			Y0	Y1	Y2	Y3	Y4	Y5	Y6	Y7		
G1	$\overline{G2A}$	$\overline{G2B}$	C	B	A										
L	X	X	X	X	X	L	L	L	L	L	L	L	L	L	NONE
X	H	X	X	X	X	L	L	L	L	L	L	L	L	L	NONE
X	X	H	X	X	X	L	L	L	L	L	L	L	L	L	NONE
H	L	L	L	L	L	H	L	L	L	L	L	L	L	L	Y0
H	L	L	L	L	H	L	H	L	L	L	L	L	L	L	Y1
H	L	L	L	H	L	L	L	H	L	L	L	L	L	L	Y2
H	L	L	L	H	H	L	L	L	H	L	L	L	L	L	Y3
H	L	L	H	L	L	L	L	L	L	H	L	L	L	L	Y4
H	L	L	H	L	H	L	L	L	L	L	H	L	L	L	Y5
H	L	L	H	H	L	L	L	L	L	L	L	H	L	L	Y6
H	L	L	H	H	H	L	L	L	L	L	L	L	H	L	Y7

X : Don't Care

**SYSTEM DIAGRAM**

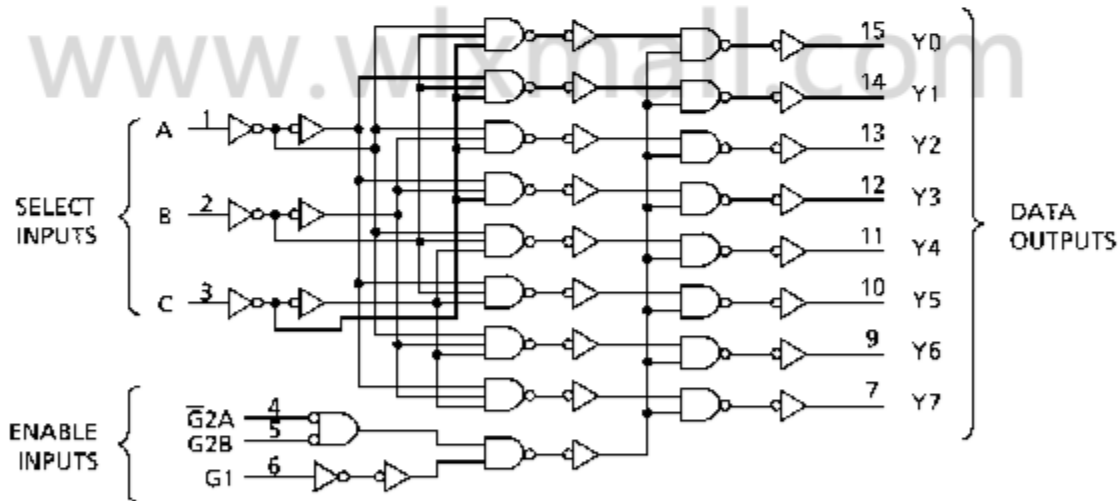

## ABSOLUTE MAXIMUM RATINGS

PARAMETER	SYMBOL	VALUE	UNIT
Supply Voltage Range	$V_{CC}$	-0.5~7	V
DC Input Voltage	$V_{IN}$	-0.5~ $V_{CC}+0.5$	V
DC Output Voltage	$V_{OUT}$	-0.5~ $V_{CC}+0.5$	V
Input Diode Current	$I_{IK}$	$\pm 20$	mA
Output Diode Current	$I_{OK}$	$\pm 20$	mA
DC Output Current	$I_{OLT}$	$\pm 25$	mA
DC $V_{CC}$ / Ground Current	$I_{CC}$	$\pm 50$	mA
Power Dissipation	$P_D$	500 (DIP)* / 180 (SOP)	mW
Storage Temperature	$T_{stg}$	-65~150	$^{\circ}C$

\*500mW in the range of  $T_a = -40^{\circ}C \sim 65^{\circ}C$ . From  $T_a = 65^{\circ}C$  to  $85^{\circ}C$  a derating factor of  $-10mW/^{\circ}C$  shall be applied until 300mW.

## RECOMMENDED OPERATING CONDITIONS

PARAMETER	SYMBOL	VALUE	UNIT
Supply Voltage	$V_{CC}$	2~6	V
Input Voltage	$V_{IN}$	0~ $V_{CC}$	V
Output Voltage	$V_{OUT}$	0~ $V_{CC}$	V
Operating Temperature	$T_{opr}$	-40~85	$^{\circ}C$
Input Rise and Fall Time	$t_r, t_f$	0~1000 ( $V_{CC} = 2.0V$ ) 0~500 ( $V_{CC} = 4.5V$ ) 0~400 ( $V_{CC} = 6.0V$ )	ns

## DC ELECTRICAL CHARACTERISTICS

PARAMETER	SYMBOL	TEST CONDITION	$V_{CC}$ (V)	$T_a = 25^{\circ}C$			$T_a = -40 \sim 85^{\circ}C$		UNIT	
				MIN.	TYP.	MAX.	MIN.	MAX.		
High - Level Input Voltage	$V_H$		2.0	1.50	—	—	1.50	—	V	
			4.5	3.15	—	—	3.15	—		
			6.0	4.20	—	—	4.20	—		
Low - Level Input Voltage	$V_{IL}$		2.0	—	—	0.50	—	0.50	V	
			4.5	—	—	1.35	—	1.35		
			6.0	—	—	1.80	—	1.80		
High - Level Output Voltage	$V_{OH}$	$V_N = V_H$ or $V_{IL}$	$I_{OH} = -20 \mu A$	2.0	1.9	2.0	—	1.9	—	V
				4.5	4.4	4.5	—	4.4	—	
			$I_{OH} = -4$ mA $I_{OH} = -5.2$ mA	4.5	4.18	4.31	—	4.13	—	
				6.0	5.68	5.80	—	5.63	—	
Low - Level Output Voltage	$V_{OL}$	$V_N = V_H$ or $V_{IL}$	$I_{OL} = 20 \mu A$	2.0	—	0.0	0.1	—	0.1	V
				4.5	—	0.0	0.1	—	0.1	
			$I_{OL} = 4$ mA $I_{OL} = 5.2$ mA	4.5	—	0.17	0.26	—	0.33	
				6.0	—	0.18	0.26	—	0.33	
Input Leakage Current	$I_{IN}$	$V_{IN} = V_{CC}$ or GND	6.0	—	—	$\pm 0.1$	—	$\pm 1.0$	$\mu A$	
Quiescent Supply Current	$I_{CC}$	$V_{IN} = V_{CC}$ or GND	6.0	—	—	4.0	—	40.0		

AC ELECTRICAL CHARACTERISTICS (  $C_L = 15\text{pF}$ ,  $V_{CC} = 5\text{V}$ ,  $T_a = 25^\circ\text{C}$ , Input  $t_r = t_f = 6\text{ns}$  )

PARAMETER	SYMBOL	TEST CONDITION	MIN.	TYP.	MAX.	UNIT
Output Transition Time	$t_{ILF}$ $t_{THL}$		—	4	8	ns
Propagation Delay Time (A, B, C—Y)	$t_{PLH}$ $t_{PHL}$		—	14	26	
Propagation Delay Time (G, $\bar{G}$ —Y)	$t_{PLH}$ $t_{PHL}$		—	14	26	

AC ELECTRICAL CHARACTERISTICS (  $C_L = 50\text{pF}$ , Input  $t_r = t_f = 6\text{ns}$  )

PARAMETER	SYMBOL	TEST CONDITION	$T_a = 25^\circ\text{C}$			$T_a = -40 \sim 85^\circ\text{C}$		UNIT	
			$V_{CC}$ (V)	MIN.	TYP.	MAX.	MIN.		MAX.
Output Transition Time	$t_{TIL}$ $t_{THL}$		2.0	—	30	75	—	95	ns
			4.5	—	8	15	—	19	
			6.0	—	7	13	—	16	
Propagation Delay Time (A, B, C—Y)	$t_{PLH}$ $t_{PHL}$		2.0	—	50	150	—	190	ns
			4.5	—	17	30	—	38	
			6.0	—	15	26	—	32	
Propagation Delay Time (G, $\bar{G}$ —Y)	$t_{PLH}$ $t_{PHL}$		2.0	—	50	150	—	190	ns
			4.5	—	17	30	—	38	
			6.0	—	15	26	—	32	
Input Capacitance	$C_{IV}$		—	5	10	—	10	pF	
Power Dissipation Capacitance	$C_{PD}$ (1)		—	53	—	—	—		

Note (1)  $C_{PD}$  is defined as the value of the internal equivalent capacitance which is calculated from the operating current consumption without load.

Average operating current can be obtained by the equation :

$$I_{CC}(\text{opr}) = C_{PD} \cdot V_{CC} \cdot f_{IV} + I_{CC}$$

www.wlxmall.com

**DIP 16PIN PACKAGE DIMENSIONS (DIP16-P-300-2.54A)**

Unit in mm

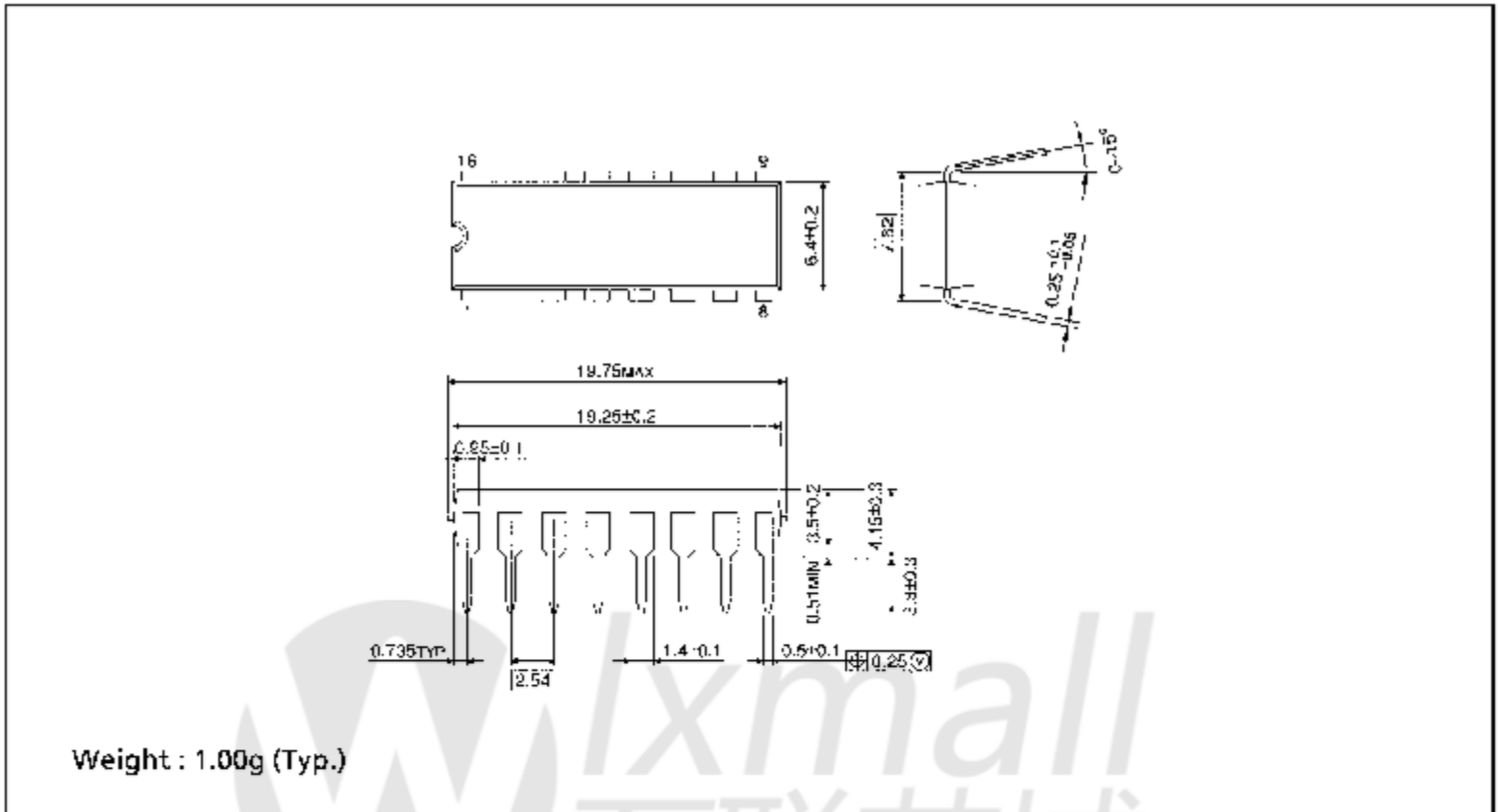

**SOP 16PIN (200mil BODY) PACKAGE DIMENSIONS (SOP16-P-300-1.27)**

Unit in mm

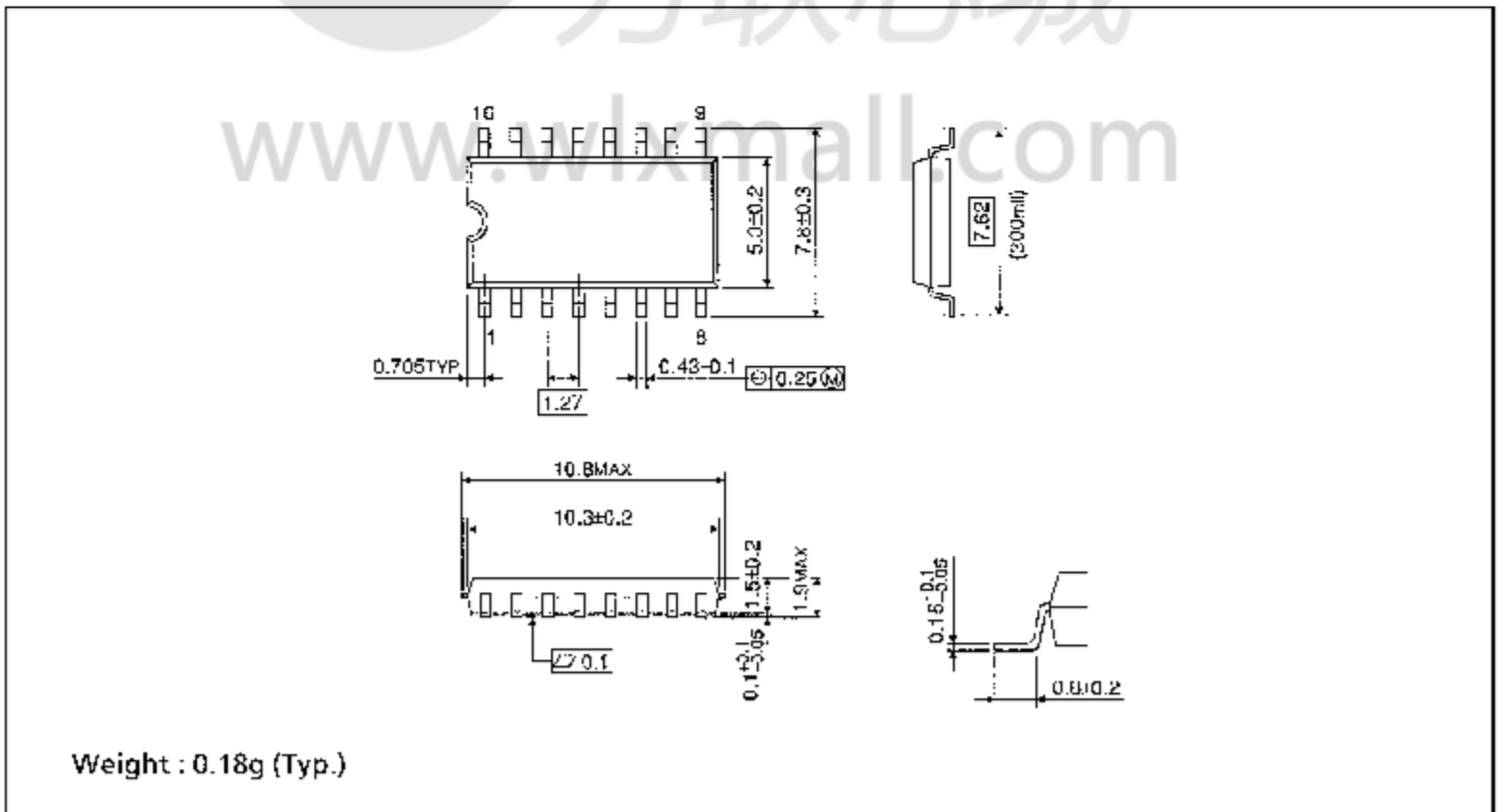

**RESTRICTIONS ON PRODUCT USE**

000/0/LUA

- TOSHIBA is continually working to improve the quality and reliability of its products. Nevertheless, semiconductor devices in general can malfunction or fail due to their inherent electrical sensitivity and vulnerability to physical stress. It is the responsibility of the buyer, when utilizing TOSHIBA products, to comply with the standards of safety in making a safe design for the entire system, and to avoid situations in which a malfunction or failure of such TOSHIBA products could cause loss of human life, bodily injury or damage to property. In developing your designs, please ensure that TOSHIBA products are used within specified operating ranges as set forth in the most recent TOSHIBA products specifications. Also, please keep in mind the precautions and conditions set forth in the "Handling Guide for Semiconductor Devices," or "TOSHIBA Semiconductor Reliability Handbook" etc..
- The TOSHIBA products listed in this document are intended for usage in general electronics applications (computer, personal equipment, office equipment, measuring equipment, industrial robotics, domestic appliances, etc.). These TOSHIBA products are neither intended nor warranted for usage in equipment that requires extraordinarily high quality and/or reliability or a malfunction or failure of which may cause loss of human life or bodily injury ("Unintended Usage"). Unintended Usage include atomic energy control instruments, airplane or spaceship instruments, transportation instruments, traffic signal instruments, combustion control instruments, medical instruments, all types of safety devices, etc.. Unintended Usage of TOSHIBA products listed in this document shall be made at the customer's own risk.
- The products described in this document are subject to the foreign exchange and foreign trade laws.
- The information contained herein is presented only as a guide for the applications of our products. No responsibility is assumed by TOSHIBA CORPORATION for any infringements of intellectual property or other rights of the third parties which may result from its use. No license is granted by implication or otherwise under any intellectual property or other rights of TOSHIBA CORPORATION or others.
- The information contained herein is subject to change without notice.