

24-V Input Voltage, 200-mA Output Current Low Quiescent Current LDO

Features

- 6-V to 24-V Input Voltage
- Fixed 5-V Output Voltage
- $\pm 2\%$ Output Accuracy over Line Regulation, Load Regulation, and Operating Temperature Range
- 4.2- μA Low Quiescent Current
- 200-mA Maximum Output Current
- 180-mV Typically Dropout Voltage at 50 mA
- PSRR:
 - 60 dB at 1 kHz
 - 56 dB at 10 kHz
- Stable with a Minimum 2.2- μF Ceramic Capacitor
- Built-in Soft Start Control
- Integrated Protection:
 - Over-Current Protection
 - Output Short-Circuit to Ground Protection
 - Over-Temperature Protection
- Junction Temperature Range: -40°C to $+125^{\circ}\text{C}$
- Package Option:
 - SOT23-5

Applications

- Battery-Powered Handheld Devices
- POS and Power Tools
- Meters and Smoke Detector
- Industrial Control
- Low Power Wireless and IoT Modules

Description

The TPL8020U50 product is a wide input range and low quiescent current low dropout linear voltage regulator. The device supports an input voltage of 6 V to 24 V and provides maximum 200-mA output current. It is stable with a minimum 2.2- μF ceramic capacitor.

The TPL8020U50 features a high PSRR with 56 dB at 10 kHz, which can significantly reduce the voltage ripple generated from the previous power stage.

The TPL8020U50 implements a low quiescent current with only 4.2- μA , which makes the TPL8020U50 a good choice for the battery-powered portable devices.

Short to ground protection, over-current protection, and over-temperature protection can ensure the system reliability under different server conditions.

The TPL8020U50 is a 5-V fixed output LDO with $\pm 2\%$ accuracy over full operating conditions. The device provides a SOT23-5 package with guaranteed operating temperature range from -40°C to $+125^{\circ}\text{C}$.

Typical Application Circuit

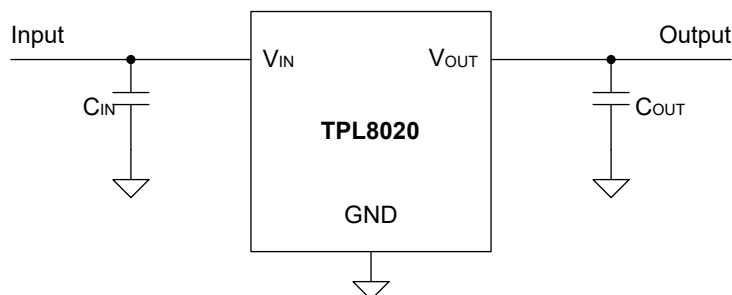

Table of Contents

Features	1
Applications	1
Description	1
Typical Application Circuit	1
Product Family Table	3
Revision History	3
Pin Configuration and Functions	4
Specifications	5
Absolute Maximum Ratings	5
ESD, Electrostatic Discharge Protection.....	5
Recommended Operating Conditions.....	5
Thermal Information.....	5
Electrical Characteristics.....	6
Typical Performance Characteristics.....	7
Detailed Description	9
Overview.....	9
Functional Block Diagram.....	9
Feature Description.....	9
Application and Implementation	10
Application Information	10
Typical Application.....	10
Layout	11
Layout Guideline.....	11
Tape and Reel Information	12
Package Outline Dimensions	13
SOT23-5.....	13
Order Information	14
IMPORTANT NOTICE AND DISCLAIMER	15

**24-V Input Voltage, 200-mA Output Current Low Quiescent Current
LDO****Product Family Table**

Orderable Part Number	Output Voltage	Package
TPL8020U50-S5TR	Fixed 5.0 V	SOT23-5

Revision History

Revision	Notes
Rev.Pre.0	Preliminary revision.
Rev.A.0	Initial released.

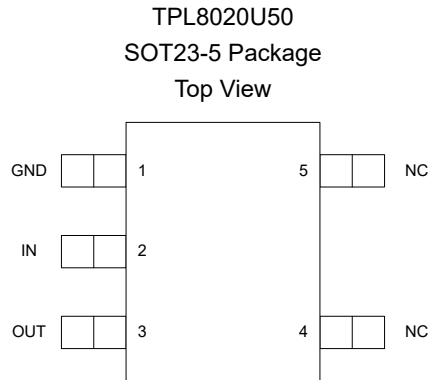
Pin Configuration and Functions**Table 1. Pin Functions: TPL8020U50**

Pin No.	Name	I/O	Description
1	GND	-	Ground reference pin. Connect GND pin to PCB ground plane directly.
2	IN	I	Input voltage pin.
4,5	NC	-	No connection.
3	OUT	O	Regulated output voltage pin.

24-V Input Voltage, 200-mA Output Current Low Quiescent Current LDO

Specifications

Absolute Maximum Ratings

Parameter		Min	Max	Unit
V _{IN}	Input Voltage	-0.3	28	V
V _{OUT}	Output Voltage	-0.3	6	V
V _{OUT}	Output Voltage, 100 ms	-0.3	24	V
T _J	Maximum Junction Temperature	-40	150	°C
T _{STG}	Storage Temperature Range	-65	150	°C
T _L	Lead Temperature (Soldering 10 sec)		260	°C

(1) Stresses beyond those listed under Absolute Maximum Ratings may cause permanent damage to the device. Exposure to any Absolute Maximum Rating condition for extended periods may affect device reliability and lifetime.

(2) All voltage values are with respect to GND.

ESD, Electrostatic Discharge Protection

Parameter		Condition	Minimum Level	Unit
HBM	Human Body Model ESD	ANSI/ESDA/JEDEC JS-001 ⁽¹⁾	±2	kV
CDM	Charged Device Model ESD	ANSI/ESDA/JEDEC JS-002 ⁽²⁾	±1	kV

(1) JEDEC document JEP155 states that 500-V HBM allows safe manufacturing with a standard ESD control process.

(2) JEDEC document JEP157 states that 250-V CDM allows safe manufacturing with a standard ESD control process.

Recommended Operating Conditions

Parameter		Min	Max	Unit
V _{IN}	Input Voltage	6	24	V
V _{OUT}	Output Voltage	0	5	V
I _{OUT}	Output Current	0	200	mA
T _J	Operating Junction Temperature Range	-40	125	°C
P _D	Power Dissipation (SOT23-5 Package)	0	300	V _{IN}

Thermal Information

Package Type	θ _{JA}	θ _{Jc}	Unit
SOT23-5	220	60	°C/W

24-V Input Voltage, 200-mA Output Current Low Quiescent Current LDO

Electrical Characteristics

All test conditions: $-40^{\circ}\text{C} \leq T_J \leq 125^{\circ}\text{C}$; typically, $T_J = 25^{\circ}\text{C}$, $V_{IN} = 6\text{ V}$, $C_{OUT} = 2.2\ \mu\text{F}$, unless otherwise noted.

Parameter		Conditions	Min	Typ	Max	Unit
Supply Input Voltage and Current						
V_{IN}	Input Voltage Range		6		24	V
I_Q	Quiescent Current	$I_{OUT} = 0\text{ mA}$, $T_J = +25^{\circ}\text{C}$		4.2	5	μA
		$I_{OUT} = 0\text{ mA}$, $T_J = -40^{\circ}\text{C} + 25^{\circ}\text{C}$		4.2	7	μA
		$I_{OUT} = 200\text{ mA}$		600		μA
Regulated Output Voltage and Current						
V_{OUT}	Output Voltage Accuracy	$T_J = +25^{\circ}\text{C}$		1%		
		$-40^{\circ}\text{C} \leq T_J \leq +125^{\circ}\text{C}$	-2%		2%	
ΔV_{OUT}	Line Regulation	$V_{IN} = 6\text{ V to } 24\text{ V}$, $I_{OUT} = 1\text{ mA}$		3	15	mV
	Load Regulation	$I_{OUT} = 1\text{ mA to } 200\text{ mA}$		10	30	mV
$V_{DO}^{(1)}$	Dropout Voltage	$I_{OUT} = 50\text{ mA}$		180	300	mV
		$I_{OUT} = 200\text{ mA}$		720	1200	mV
I_{OUT}	Output Current	V_{OUT} in regulation	0		200	mA
I_{CL}	Output Current Limit	$V_{OUT} = 0.9 \times V_{OUT(NOM)}$	210	480	500	mA
PSRR	Power Supply Rejection Ratio	$I_{OUT} = 100\text{ mA}$, $f = 1\text{ kHz}$		60		dB
		$I_{OUT} = 100\text{ mA}$, $f = 10\text{ kHz}$		56		dB
		$I_{OUT} = 100\text{ mA}$, $f = 1\text{ MHz}$		30		dB
V_N	Output Noise Voltage	$I_{OUT} = 10\text{ mA}$, BW = 10 Hz to 100 kHz		182		μV_{RMS}
Operating Temperature Range						
T_{SD}	Thermal Shutdown Temperature			166		$^{\circ}\text{C}$
	Hysteresis			20		$^{\circ}\text{C}$

(1) Specified by design.

Typical Performance Characteristics

All test conditions: $V_{IN} = 6\text{ V}$, whichever is greater; $C_{OUT} = 2.2\ \mu\text{F}$, $T_A = +25^\circ\text{C}$, unless otherwise noted.

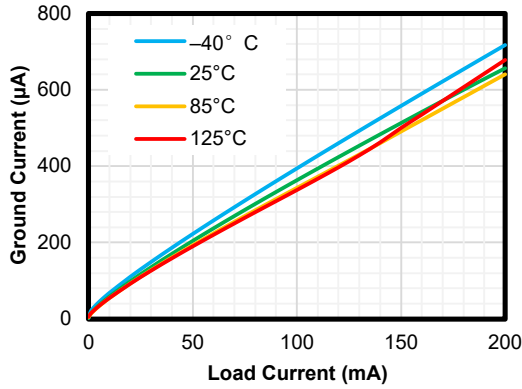

Figure 1. Quiescent Current vs Output Current

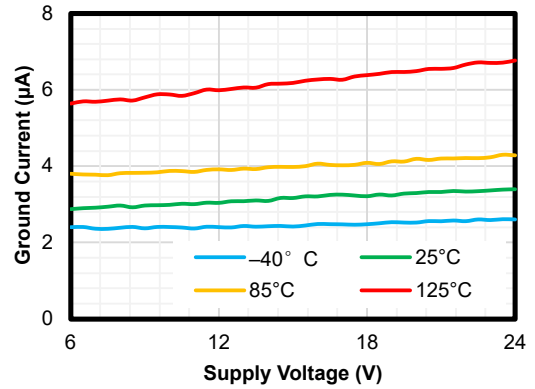

Figure 2. Quiescent Current vs Input Voltage

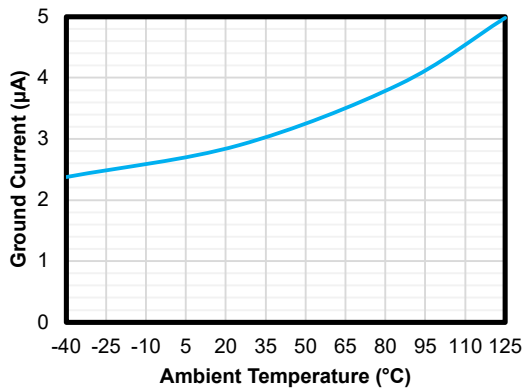

Figure 3. Quiescent Current vs Ambient Temperature

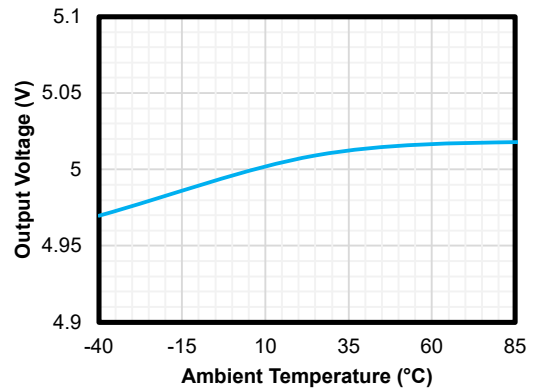

Figure 4. Output Accuracy vs Ambient Temperature

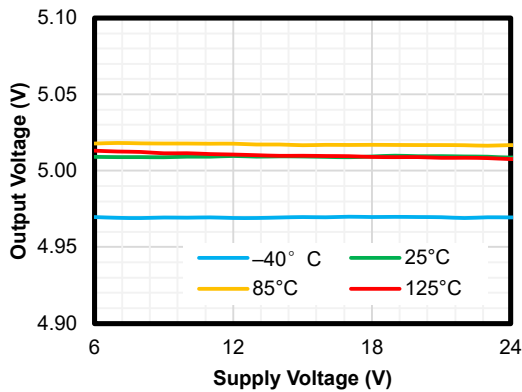

Figure 5. Line Regulation

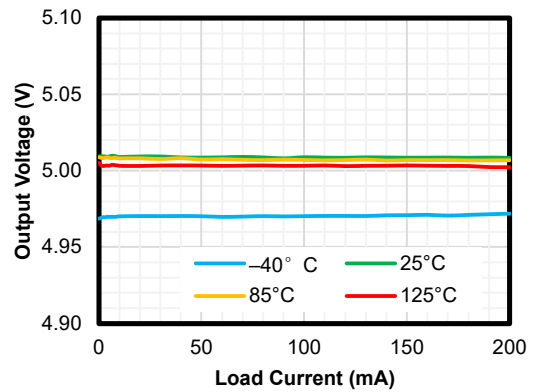
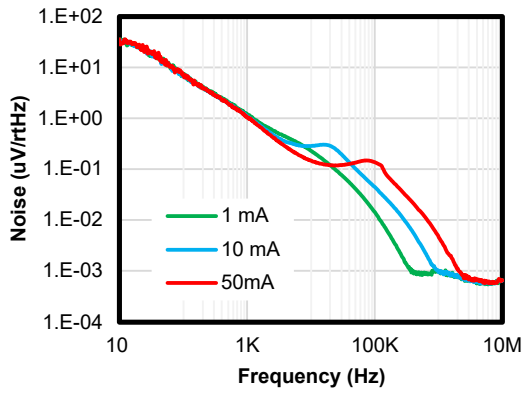
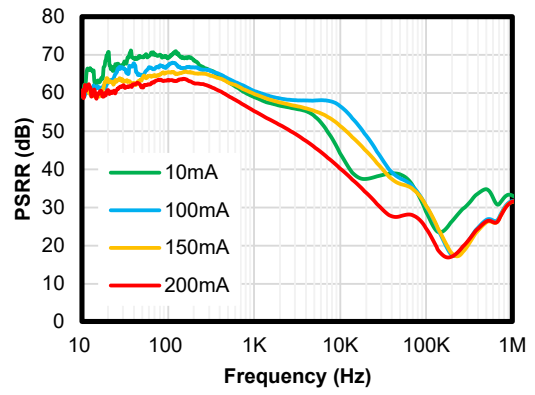

Figure 6. Load Regulation

24-V Input Voltage, 200-mA Output Current Low Quiescent Current LDO**Figure 7. Output Noise****Figure 8. PSRR**

Detailed Description

Overview

The TPL8020U50 product is a wide input range and low quiescent current linear voltage regulator. The device supports an input voltage of 6 V to 24 V and provides maximum 200 mA output current. It is stable with a minimum 2.2- μ F ceramic capacitor.

Functional Block Diagram

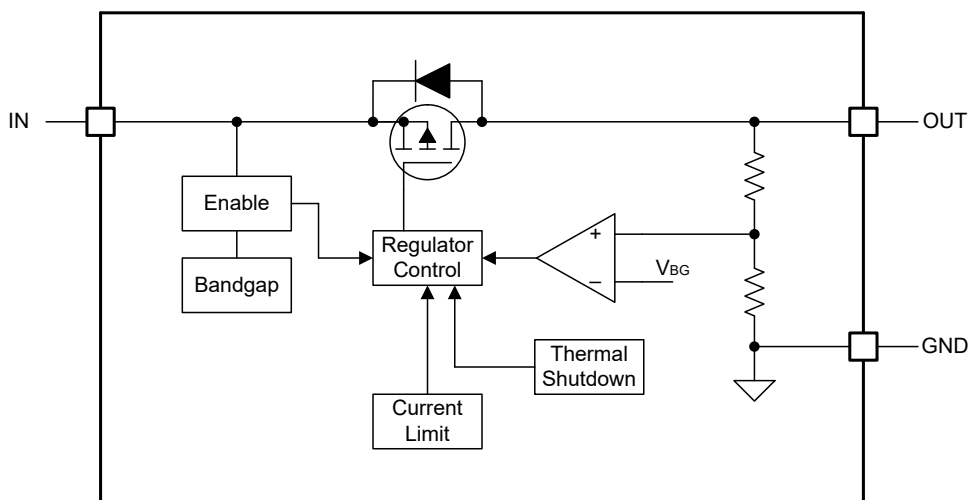

Figure 9. Functional Block Diagram

Feature Description

Regulated Output Voltage

The TPL8020U50 is a 5-V fixed output LDO. When a voltage of 6 V to 24 V is applied to the IN pin, a stable 5 V can be obtained at the output.

Over-Current Protection

The TPL8020U50 integrates an over-current protection that helps to protect the regulator during over-load or short-circuit to ground conditions. The output voltage is not regulated when the device is in the over current mode and the value is $V_{OUT} = I_{CL} \times R_{LOAD}$.

Over-Temperature Protection

The over-temperature protection starts to work when the junction temperature exceeds the thermal shutdown (TSD) threshold, which turns off the regulator immediately. The regulator turns on again when the device cools down and the junction temperature falls below the value which equals to thermal shutdown threshold minus thermal shutdown hysteresis.

According to the Recommended Operating Conditions table, the junction temperature range should be limited; continuously operating above the junction temperature range will reduce the device's lifetime.

Application and Implementation

Note

Information in the following application sections is not part of the 3PEAK's component specification and 3PEAK does not warrant its accuracy or completeness. 3PEAK's customers are responsible for determining suitability of components for their purposes. Customers should validate and test their design implementation to confirm system functionality.

Application Information

The TPL8020U50 is a 24-V 200-mA low dropout linear regulator with a 2.5- μ A low quiescent current. The following application schematic shows a typical usage of TPL8020U50.

Typical Application

Figure 10 shows the typical application schematics of TPL8020U50.

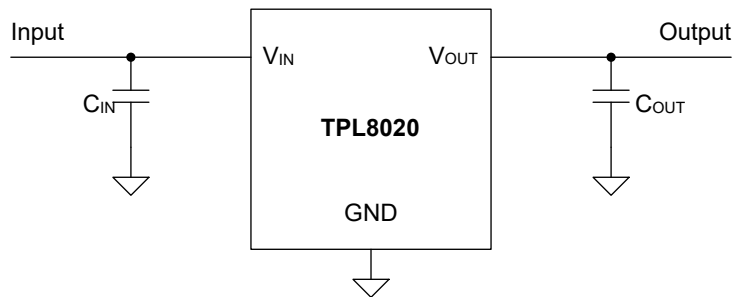

Figure 10. Typical Application Schematic of Fixed Output

Input Capacitor and Output Capacitor

3PEAK recommends adding a 2.2- μ F or greater capacitor with a 0.1- μ F bypass capacitor in parallel at the IN pin to keep the input voltage stable. An aluminum electrolytic capacitor or other capacitors with high capacitance is suggested for the system power with a large voltage spike. The voltage rating of the capacitors must be greater than the maximum input voltage.

To ensure loop stability, the TPL8020U50 series requires an output capacitor with an effective capacitance value of 2.2 μ F to 22 μ F. 3PEAK recommends selecting an X7R-type 4.7- μ F ceramic capacitor with low ESR over the temperature range.

Both input capacitors and output capacitors must be placed as close to the device pins as possible.

Power Dissipation

During normal operation, LDO junction temperature should meet the requirement in the [Recommended Operating Conditions](#) table. Using the below equations to calculate the power dissipation and estimate the junction temperature.

The power dissipation can be calculated using [Equation 1](#).

$$P_D = (V_{IN} - V_{OUT}) \times I_{OUT} + V_{IN} \times I_{GND} \quad (1)$$

The junction temperature can be estimated using [Equation 2](#). θ_{JA} is the junction-to-ambient thermal resistance.

$$T_J = T_A + P_D \times \theta_{JA} \quad (2)$$

Layout

Layout Guideline

- Both input capacitors and output capacitors must be placed as close to the device pins as possible, and vias between capacitors and device power pins must be avoided.
- It is recommended to bypass the input pin to the ground with a 0.1- μ F bypass capacitor. The loop area formed by the bypass capacitor connection, the IN pin, and the GND pin of the system must be as small as possible.
- It is recommended to use wide and thick copper to minimize I \times R drop and heat dissipation.

Tape and Reel Information

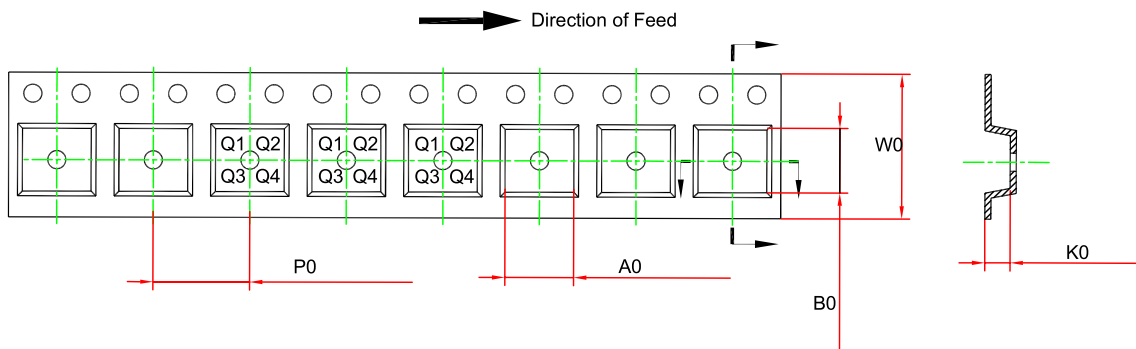
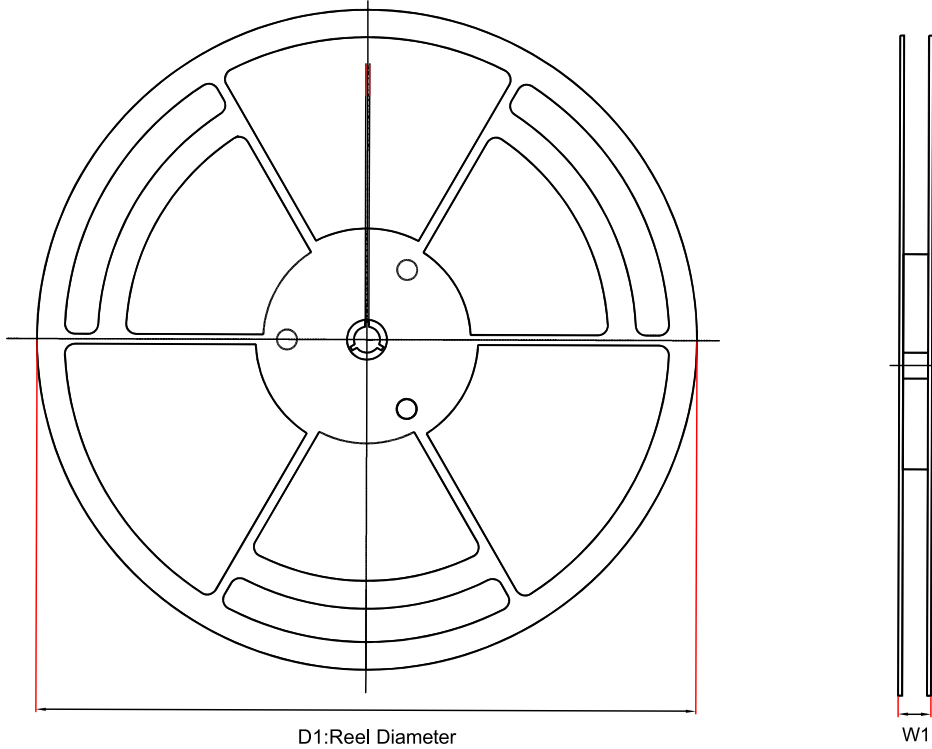

Order Number	Package	D1 (mm)	W1 (mm)	A0 (mm)	B0 (mm)	K0 (mm)	P0 (mm)	W0 (mm)	Pin1 Quadrant
TPL8020U50-S5TR	SOT23-5	180	13.1	3.2	3.2	1.4	4	8	Q3

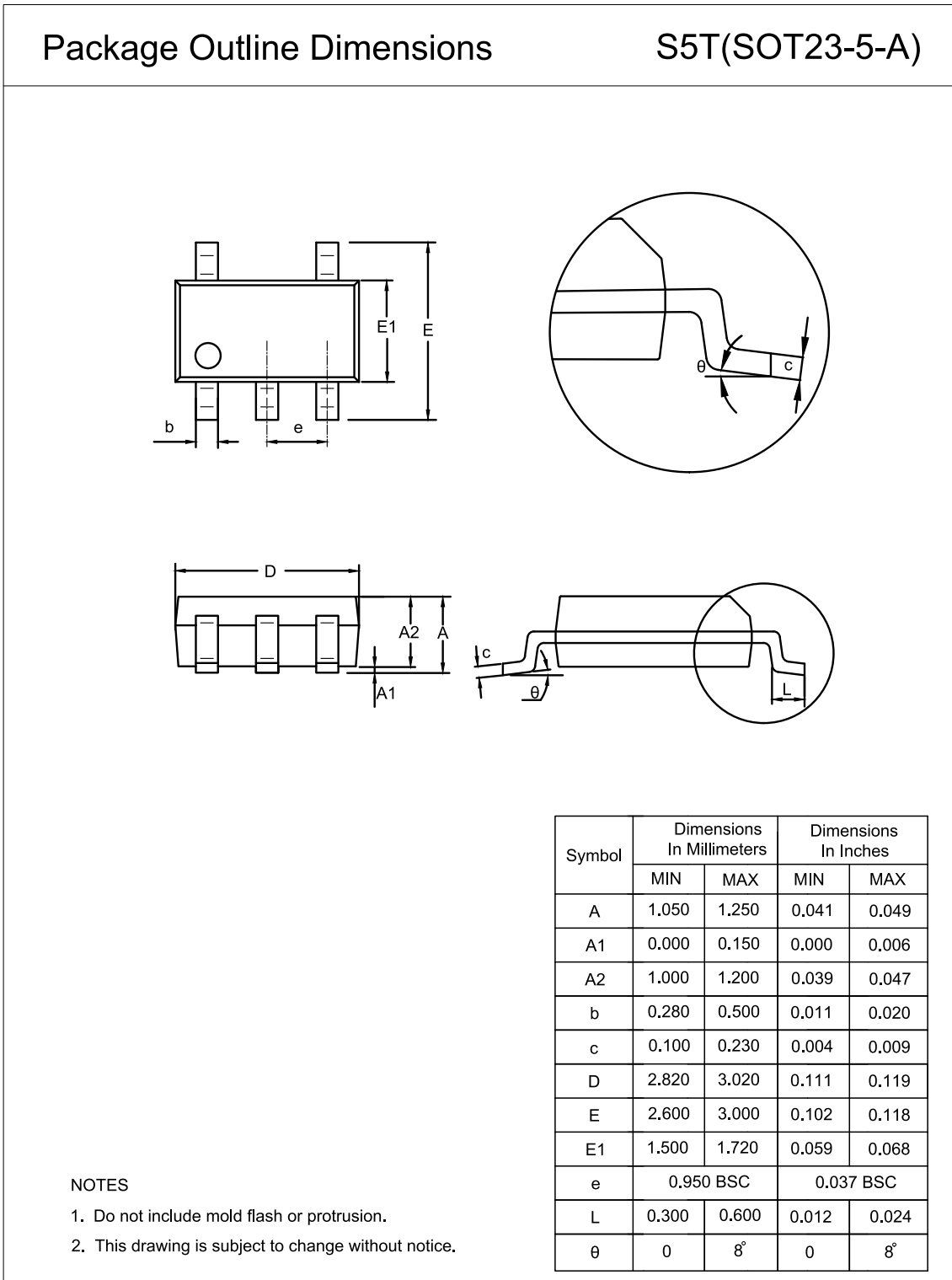
Package Outline Dimensions
SOT23-5

24-V Input Voltage, 200-mA Output Current Low Quiescent Current LDO**Order Information**

Order Number	Operating Temperature Range	Package	Marking Information	MSL	Transport Media, Quantity	Eco Plan
TPL8020U50-S5TR	-40 to 125°C	SOT23-5	LCV	MSL3	Tape and Reel, 3,000	Green

Green: 3PEAK defines "Green" to mean RoHS compatible and free of halogen substances.

IMPORTANT NOTICE AND DISCLAIMER

Trademarks. Any of the 思瑞浦 or 3PEAK trade names, trademarks, graphic marks, and domain names("Trademarks") contained in this document/material are the property of 3PEAK. You may NOT reproduce, modify, publish, transmit or distribute any Trademark without the prior written consent of 3PEAK.

Performance Information. Performance tests or performance range contained in this document/material are results of design simulation or actual tests conducted under designated testing environment. Any differences in testing environment or simulation environment, including but not limited to testing method, testing process or testing temperature, may affect actual performance of the product.

Forward-Looking Statements. The information in this document/material may contain forward-looking statements, except for statements or descriptions of historical facts. These forward-looking statements are based upon our current understanding of our industry, management philosophy and certain assumptions and speculative calculations. These forward-looking statements are subject to risks and uncertainties and our actual results may differ. Please do not rely solely on the above information to make your business decisions.

Disclaimer. 3PEAK provides technical and reliability data (including data sheets), design resources (including reference designs), application or other design recommendations, networking tools, security information and other resources "As Is". 3PEAK makes no warranty as to the absence of defects, and makes no warranties of any kind, express or implied, including, without limitation, implied warranties as to merchantability, fitness for a particular purpose or non-infringement of any third-party's intellectual property rights.

This page intentionally left blank